

MANUALE D'USO

■ STAFFA A PAVIMENTO "MERCURY"
FLOOR STAND "MERCURY"
COD. SCD500025 - SCD500026 - SCD500027



by



Tecnosystemi S.p.A.

via dell'Industria, 2/4 - Z.I. San Giacomo di Veglia
31029 Vittorio Veneto (Treviso) - Italia
Tel +39 0438.500044 - Fax +39 0438.501516
Numero Verde 800 904474 (only for Italy)
email: info@tecnosystemi.com

C.F. - P. IVA - R.I.TV IT02535780247 Cap. Soc. € 5.000.000,00 i.v.

www.tecnosystemi.com



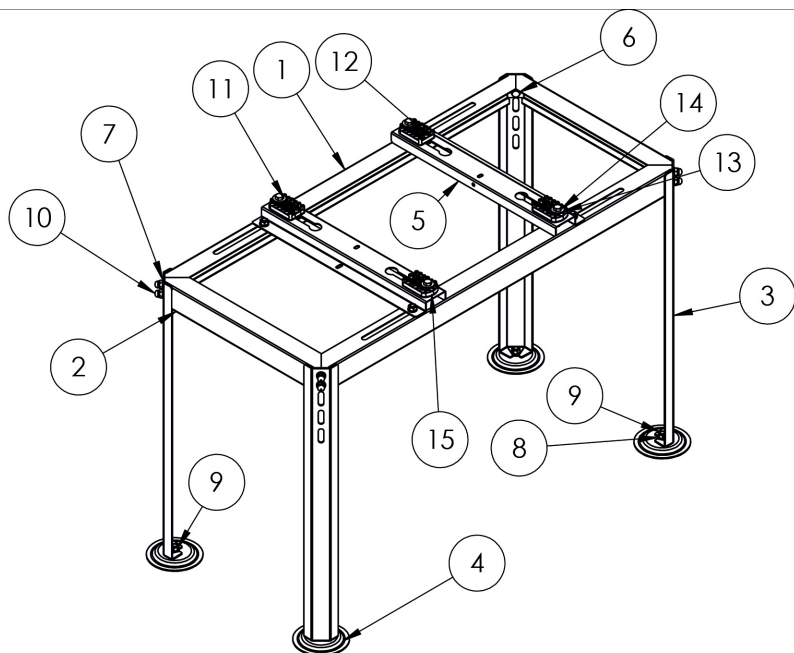



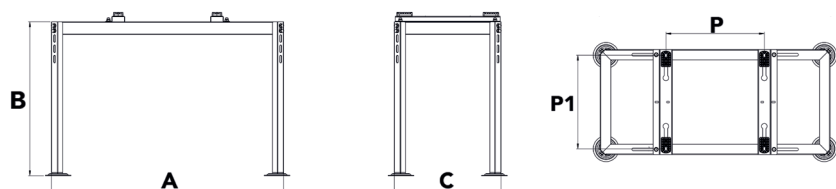





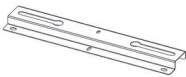

ELENCO COMPONENTI / LIST OF COMPONENTS



DIMENSIONI / DIMENSIONS



CODICE / CODE	DESCRIZIONE / DESCRIPTION	A (mm)	B (mm)	C (mm)	P (mm)	P1 (mm)	PORTATA (kg) / WEIGHT CAPACITY
SCD500025	STAFFA A PAVIMENTO MERCURY 440 / <i>FLOOR STAND MERCURY 440</i>	895	600	410	324/715	220/360	100
SCD500026	STAFFA A PAVIMENTO MERCURY 480 / <i>FLOOR STAND MERCURY 480</i>	940	600	480	324/755	280/435	150
SCD500027	STAFFA A PAVIMENTO MERCURY 550 / FLOOR STAND MERCURY 550	1010	600	550	385/825	310/510	200

NUM. ART. / NUM. ITEM	COMPONENTE / COMPONENT	DESCRIZIONE / DESCRIPTION	QUANTITÀ / QUANTITY
1		CORNICE FRONTALE LUNGHEZZA 850 / FRONT FRAME LENGTH 850	2
2		CORNICE LATERALE LUNGHEZZA 440 / LATERAL FRAME LENGTH 440	2
3		GAMBA LUNGHEZZA 440 / LEG LENGTH 440	4
4		PIEDINO BUGNATO Ø 100 / EMBOSSED FOOT Ø 100	4
5		TRAVERSA LUNGHEZZA 440 / CROSSBAR LENGTH 440	2
6		BULLONE T.E.M8 x 16 / HEX HEAD BOLTS M8 x 16	16
7		RONDELLA PIANA M8 / M8 FLAT WASHER	12
8		RONDELLA ZIGRINATA M8 / M8 GROOVED WASHER	16
9		DADO MEDIO M8 / M8 MEDIUM NUT	8
10		DADO ESAGONALE CIECO M CALOTTA SFERICA UNI5721 / M8 BLIND HEX NUT SPHERICAL CAP UNI5721	8
11		ANTIVIBRANTE SOFT SOFT ANTI-VIBRATION PADS	2
12		ANTIVIBRANTE HARD / HARD ANTI-VIBRATION PADS	2
13		ROSETTA M8 x 24 x 2 / WASHER M8 x 24 x 2	8
14		BULLONE T.E. 4.8 M8 x 35 UNI5739 ZINC. BIANCO / HEX HEAD BOLTS 4.8 M8 x 35 UNI5739 ZINC. WHITE	4
15		DADO M8 AUTOBLOCCANTE BASSI ZNB UNI 7474 DIN985 / M8 LOW LOCK NUT ZNB UNI 7474 DIN985	4

ASSEMBLAGGIO MESSA IN OPERA / ASSEMBLY AND COMMISSIONING

STEP 1

Posizionarsi su un piano di lavoro ed allineare i fori della cornice frontale (particolare 1) con le asole della cornice laterale (particolare 2) come raffigurato nel dettaglio A, in modo che le superfici superiori siano planari, come raffigurato nel dettaglio B.

ATTENZIONE: LE ASOLE SONO INTERNE E I FORI SONO ESTERNI.

Place on a level work surface and line up the holes of the front frame (detail 1) with the eyelets of the lateral frame (detail 2) as shown in detail A so that the upper surfaces are flat, as shown in detail B.

WARNING: THE EYELETS ARE INTERNAL AND THE HOLES ARE EXTERNAL.

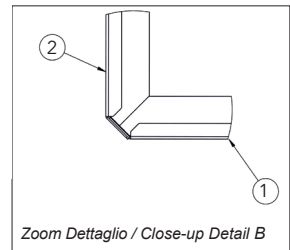
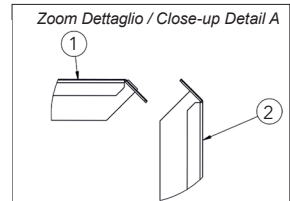
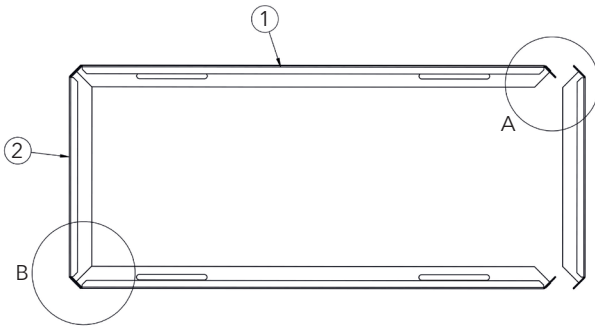

STEP 2

Allineare le asole delle gambe con i fori della cornice precedentemente allineati come raffigurato nel dettaglio C e fissarli tramite viteria (particolari 6, 7, 8, 10).

Line up the eyelets of the legs with the holes of the frame that have already been lined up as shown in detail C and secure them with bolts (details 6, 7, 8, 10).

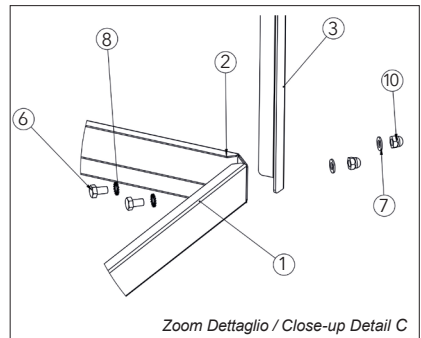
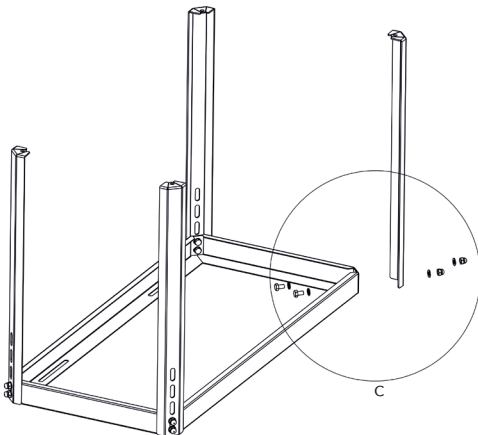

STEP 3

Allineare il foro del piedino (particolare 4) con quello della gamba (particolare 3) e fissarlo tramite apposita viteria (particolari 6, 8, 9) come raffigurato nel dettaglio D.

Line up the hole of the foot (detail 4) with the one on the leg (detail 3) and secure it using suitable bolts (details 6, 8, 9) as shown in detail D.

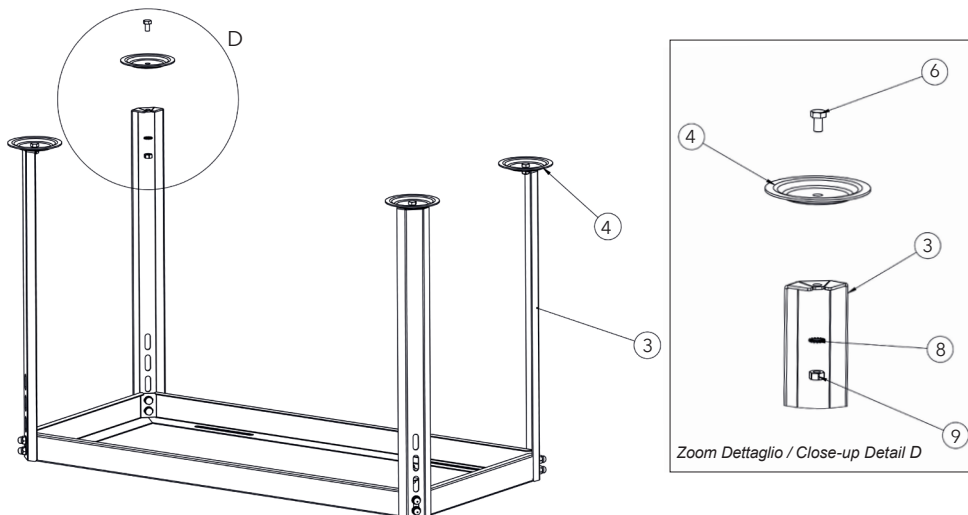

STEP 4

Allineare l'asola laterale della traversa (particolare 5) con l'asola della cornice (particolare 1). Regolare la larghezza delle due traverse tramite le asole e fissarle tramite apposita viteria (viteria 6, 7, 8, 9) come raffigurato nel dettaglio E.

Line up the lateral eyelet of the crossbar (detail 5) with the slot on the frame (detail 1). Adjust the length of the two crossbars using the slots and secure them with suitable bolts (details 6, 7, 8, 9) as shown in detail E.

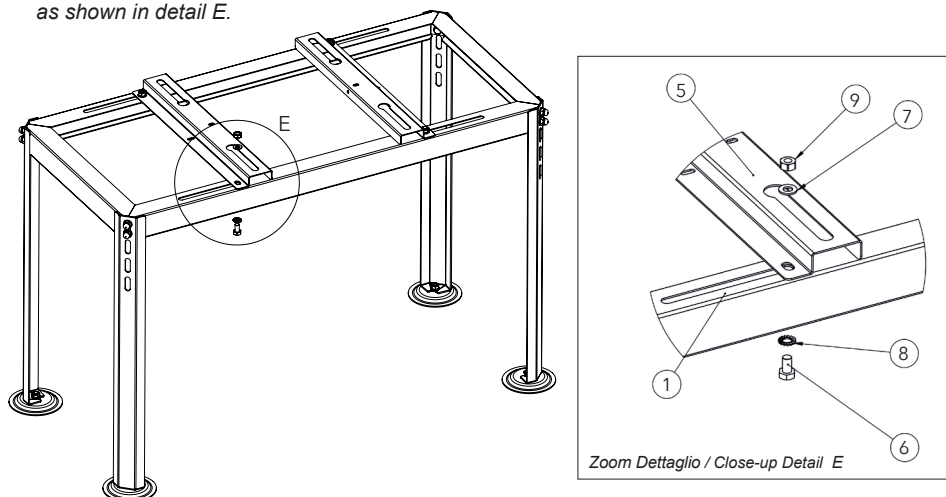

STEP 5

Fissare gli antivibranti “soft” sotto il supporto dell’unità esterna dove è collocata la ventola, e gli antivibranti “hard” sotto il supporto dove è collocato il motore.

Fissare l’unità esterna tramite apposita viteria (particolari 13, 14, 15) come raffigurato nel dettaglio AC.

ATTENZIONE: LE ASOLE SONO INTERNE E I FORI SONO ESTERNI.

Secure the “soft” anti-vibration pads under the external unit support where the fan is located and the “hard” anti-vibration pads under the support where the motor is located.

Secure the external unit using the appropriate bolts (details 13, 14, 15) as shown in detail AC.

WARNING: THE EYELETS ARE INTERNAL AND THE HOLES ARE EXTERNAL.

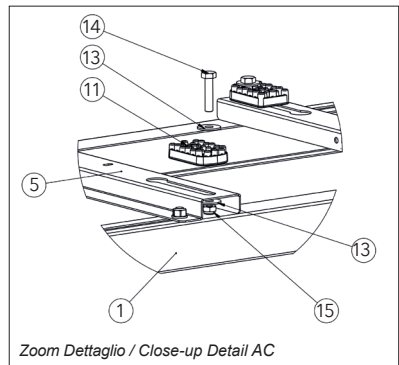
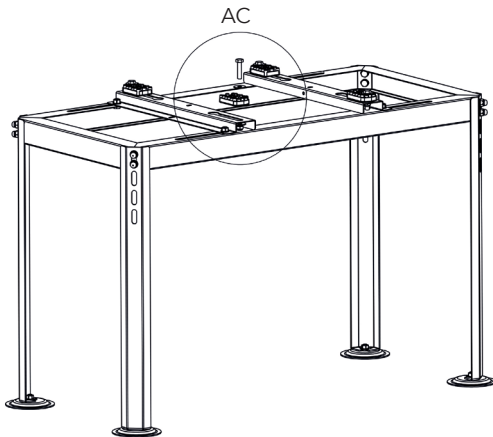

ESEMPI DI INSTALLAZIONE / INSTALLATION EXAMPLES

**ESEMPIO DI INSTALLAZIONE
CON BACINELLA BLUE RIVER /
INSTALLATION EXAMPLE
WITH BLUE RIVER TRAY**



**ESEMPIO DI INSTALLAZIONE
CON CON UNITÀ ESTERNA
INSTALLATION EXAMPLE
WITH EXTERNAL UNIT**

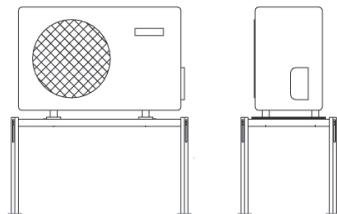

GARANZIA / WARRANTY

La garanzia ha durata di 2 anni a decorrere dalla data di consegna.

L'azienda fornitrice garantisce la qualità dei materiali impiegati e la corretta realizzazione dei componenti. La garanzia copre difetti di materiale e di fabbricazione e si intende relativa alla fornitura dei pezzi in sostituzione di qualsiasi componente che presenti difetti, senza che possa venir reclamata alcuna indennità, interesse o richiesta di danni.

La garanzia non copre la sostituzione dei componenti che risultano danneggiati per:

- trasporto non idoneo;
- installazione non conforme a quanto specificato in questo manuale di installazione uso e manutenzione;
- la non osservanza delle specifiche tecniche di prodotto;
- quant'altro non riconducibile a vizi originari del materiale o di produzione a condizione che il reclamo del cliente sia coperto dalla garanzia e notificato nei termini e modalità richiesta dal fornitore, lo stesso si impegnerà, a sua discrezione, a sostituire o riparare ciascun prodotto o le parti di questo che presentino vizi o difetti.

The warranty lasts 2 years from the date of delivery.

The supplier company guarantees the quality of the materials used and the correct construction of the components. The warranty covers defects in materials and manufacturing defects and refers to the supply of spare parts of any components featuring defects, without any compensation, interest or claim for damages.

The warranty does not cover the replacement of components damaged due to:

- *incorrect transportation;*
- *installation not compliant with that specified in this installation, use and maintenance manual;*
- *non-observance of product technical specifications;*
- *Anything else that is not linked to original faults of the material or production provided that the customer complaint is covered by the guarantee and a claim is made within the time limit and in the way requested by the supplier, the same supplier will commit, at their own discretion, to replace or repair any product or part of product showing signs of faults or defects.*

SMALTIMENTO / DISPOSAL

Alla fine della sua vita utile il prodotto non deve essere smaltito insieme ai rifiuti urbani. Può essere consegnato presso gli appositi centri di raccolta differenziata predisposti dalle amministrazioni comunali, oppure presso i rivenditori che forniscono questo servizio. Per rimarcare l'obbligo di smaltire separatamente gli elettrodomestici, sul prodotto è riportato il marchio del contenitore di spazzatura mobile barrato.



At the end of its useful life, the product must not be disposed of with household waste. It can be deposited at a dedicated recycling centre run by local councils, or at retailers who provide such a service. To highlight the requirement to dispose of household electrical items separately, there is a crossed-out waste paper basket symbol on the product.



Tecnosystemi S.p.A.
via dell'Industria, 2/4 - Z.I. San Giacomo di Veglia
31029 Vittorio Veneto (Treviso) - Italy
Phone +39 0438.500044 Fax +39 0438.501516
Numero Verde 800 904474 (only for Italy)
email: info@tecnosystemi.com

C.F. - P. IVA - R.I.TV IT02535780247 Cap. Soc. € 5.000.000,00 i.v.

www.tecnosystemi.com